



Western Cape Government • Wes-Kaapse Regering • URhulumente weNtshona Koloni

PROVINCE OF THE WESTERN CAPE

PROVINSIE WES-KAAP

IPHONDO LENTSHONA KOLONI

Provincial Gazette
Extraordinary

Buitengewone
Provinsiale Koerant

Isongezelelo
kwiGazethi yePhondo

8449

8449

8449

Friday, 18 June 2021

Vrydag, 18 Junie 2021

uLwesihlanu, 18 kweyeSilimela 2021

Registered at the Post Office as a Newspaper

As 'n Nuusblad by die Poskantoor Geregistreer

Ibhaliswe ePosini njengePhephandaba

CONTENTS

INHOUD

IZIQUATHO

(*Reprints are obtainable at Room M21, Provincial Legislature Building, 7 Wale Street, Cape Town 8001.)

(*Afskrifte is verkrygbaar by Kamer M21, Provinsiale Wetgewer-gebou, Waalstraat 7, Kaapstad 8001.)

(*Ushicilelo oLutsha lufumaneka kwigumbi M21, kwiSakhiwo sePhondo seNdlu yoWiso-Mthetho, 7 Wale Street, eKapa 8001.)

Provincial Notices

Provinsiale Kennisgewings

IZaziso zePhondo

The following Provincial Notices are published for comment:

Die volgende Provinsiale Kennisgewings word vir kommentaar gepubliseer:

Ezi zaziso zilandelayo zipapashelwe ukunika izimvo:

67 Department of Environmental Affairs and Development Planning: National Environmental Management: Protected Areas Act, 2003 (Act 57 of 2003): Notice of Intention to Declare Kenilworth Nature Reserve..... 2

67 Departement van Omgewingsake en Ontwikkelingsbeplanning: "National Environmental Management: Protected Areas Act, 2003" (Wet 57 van 2003): Kennisgewing van Voorneme om Kenilworth Natuureservaat te Verklaar 6

67 ISebe leMicimbi yokuSingqongileyo noCwangciso loPhuhliso: ULawulo lweNdalo eSingqongileyo: UMthetho wemiMandla eKhuselweyo, 2003 (Umthetho 57 ka-2003): Isaziso seNjongo yokuBhengeza iNdawo yezoLondolozo lweNdalo yaseKenilworth ... 10

68 Department of Environmental Affairs and Development Planning: National Environmental Management: Protected Areas Act, 2003 (Act 57 of 2003): Notice of Intention to Declare Twee Rivieren Nature Reserve 14

68 Departement van Omgewingsake en Ontwikkelingsbeplanning: "National Environmental Management: Protected Areas Act, 2003" (Wet 57 van 2003): Kennisgewing van Voorneme om Twee Rivieren Natuureservaat te Verklaar 16

68 ISebe leMicimbi yokuSingqongileyo noCwangciso loPhuhliso: ULawulo lweNdalo eSingqongileyo: UMthetho wemiMandla eKhuselweyo, 2003 (Umthetho 57 ka-2003): Isaziso seNjongo yokuBhengeza kweTwee Rivieren njengeNdawo yoLondolozo lweNdalo 18

PROVINCIAL NOTICES

The following Provincial Notices are published for comment.

DR H.C. MALILA,
DIRECTOR-GENERAL

Provincial Legislature Building,
Wale Street,
Cape Town.

PROVINSIALE KENNISGEWINGS

Die volgende Provinsiale Kennisgewings word vir kommentaar gepubliseer.

DR H.C. MALILA,
DIREKTEUR-GENERAAL

Provinsiale Wetgewer-gebou,
Waalstraat,
Kaapstad.

IZAZISO ZEPHONDO

Ezi zaziso zilandelayo zipapashelwe ukunika izimvo.

GQIR H.C. MALILA,
MLAWULI-JIKELELE

ISakhiwo sePhondo,
Wale Street,
eKapa.

PROVINCIAL NOTICE

P.N. 67/2021

18 June 2021

DEPARTMENT OF ENVIRONMENTAL AFFAIRS AND DEVELOPMENT PLANNING**NATIONAL ENVIRONMENTAL MANAGEMENT: PROTECTED AREAS ACT, 2003 (ACT 57 OF 2003)****NOTICE OF INTENTION TO DECLARE KENILWORTH NATURE RESERVE**

The Provincial Minister of Local Government, Environmental Affairs and Development Planning in the Western Cape—

(a) under section 33(1)(a) of the National Environmental Management: Protected Areas Act, 2003 (Act 57 of 2003), gives notice of the intention to declare the Kenilworth Nature Reserve in terms of section 23(1)(a)(i) of that Act on:

1. Remainder of Erf 65238 Kenilworth, situated in the City of Cape Town Municipality, Division of Cape, Province of the Western Cape;
In extent: 95, 7312 (Ninety-Five comma Seven Three One Two) hectares;
Held under Title Deed No T41588/2013;
2. Erf 65275 Kenilworth, situated in the City of Cape Town Municipality, Division of Cape, Province of the Western Cape;
In extent: 2, 5696 (Two comma Five Six Nine Six) hectares;
Held under Title Deed No T41588/2013; and
3. Remainder of Erf 65274 Kenilworth, situated in the City of Cape Town Municipality, Division of Cape, Province of the Western Cape;
In extent: 8 565 (Eight Thousand Five Hundred and Sixty-Five) square metres;
Held under Title Deed No T41588/2013.

The properties are situated between Doncaster Road to the north, Kromboom Parkway to the east, Wetton Road to the south and Rosmead Avenue to the west, in the suburb of Kenilworth approximately 10 kilometres south-east of Cape Town's central business district.

The boundaries of the nature reserve are reflected on Surveyor-General diagrams 3137/1882, 470/1852 and 257/1814, as set out in the Schedule, and may also be viewed at <https://www.capenature.co.za/care-for-nature/stewardship/>; and

(b) invites members of the public to submit written representations on or objections to the proposed declaration of the Kenilworth Nature Reserve within 60 days from the date of publication of this notice in the *Provincial Gazette*, by—

- (i) posting the representations or objections to:

The Chief Executive Officer
Attention: Ms M Owies
CapeNature
Private Bag X29
Gatesville 7766;

- (ii) e-mailing the representations or objections to:

mowies@capenature.co.za;

- (iii) faxing the representations or objections to:

Fax number: 086 719 3581; or

- (iv) delivering the representations or objections to:

Ms M Owies
CapeNature
Cnr Bosduif and Volstruis Streets
Bridgetown
Athlone 7764.

SCHEDULE

The numerical data of this diagram are sufficiently consistent.
(Sgd.) Max Jurisch
Examiner

S. G. Dgm. No. 3137/1882

S.G.Dgm. No. 3137/1882.

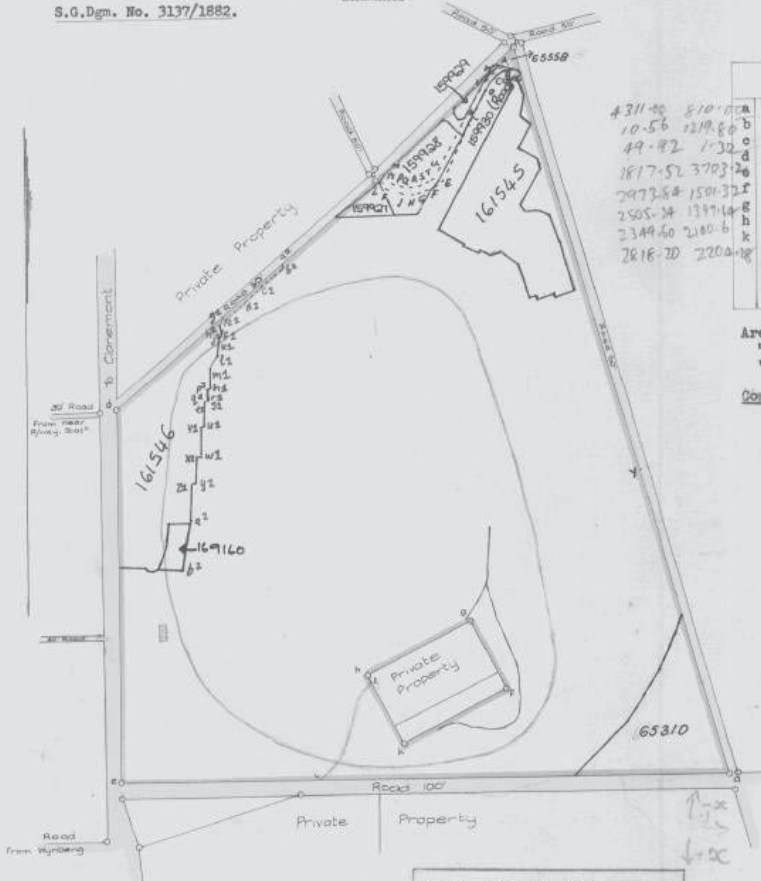

4311.40 810.00
 10.56 1118.80
 49.82 1132.00
 1817.52 3703.00
 2973.84 1501.30
 2805.34 1317.10
 2344.60 2180.60
 2818.20 2200.18

Co-ordinates	Sides	Angles
a - 399.25 + 67.90	ah 397.88	a 74.24.10
b + 0.88 - 101.65	ba 101.67	b 62.0.0
c - 4.16 - 0.11	cb 180.95	c 182.50.30
d - 4.16 + 180.84	dc 194.99	d 130.56.10
e - 151.46 + 308.60	ed 318.28	e 89.49.10
f - 247.82 + 125.11	fe 40.00	f 270.0.0
g - 208.77 + 116.47	fg 60.00	g 270.0.0
h - 195.80 + 175.05	gh 40.00	h 270.0.0
i - 234.85 + 183.69	hi 60.00	i 270.0.0
	if 125.44	ifk 129.49.10
	ke 150.19	kfe 201.14.50
		kan 7.1.40
		caf 21.54.20

Area of fig. a-e 135^{sq} 15^{sq}
 " " " f-k 4.0
 " on the ground 131-15

Condition. A road must be reserved to give access to the farm f - k.

ERF 65238 CAPE TOWN
 at Kentlorn

Scale of Cape Roads, 1:7500
 112, 2271 ha

The above figure a - e surrounding the figure f, g, h, k, represents 131 Morgen 15 Square Rods of ground, situate in the Cape Division, Field Cornetcy of Newlands on the Claremont Flats.

Bounded North by a Road 50' wide
 East " Do. Do.
 South " Do. 100' wide
 West " Do. Do.

Framed from actual Survey,
 (Sgd.) Wm. de Smidt Junr.
 Gov. Land Surveyor,
 24 November 1882.

Note: The land f g h k is Quitrent granted 3rd January, 1815 to Moses Eysen.

Copied from the diagram relating to
 Title Deed No. C. P. 18. 1,
 dated 18th December 1882, in favour of
 Chairman in Trust for Jockey Club
 W. G. Hardwick
 SURVEYOR-GENERAL
 CAPE TOWN,
 4. 6. 1951.

Road lettered along Bdy. X. Y.
 closed. Vide T.C.'s Notice d.d. 1993-05-25
 File S/399A/48 p.72
 Rat
 for SURVEYOR-GENERAL 1929.07.23
 DATE

Cape Town Sheet N 18.

Vol 18. 24/192
 152 + 151

M 3160
 M 1425
 ERF 65238
 Cont. 263
 Ref. C6
 FOR ENDORSEMENTS
 SEE BACK OF DIAGRAM

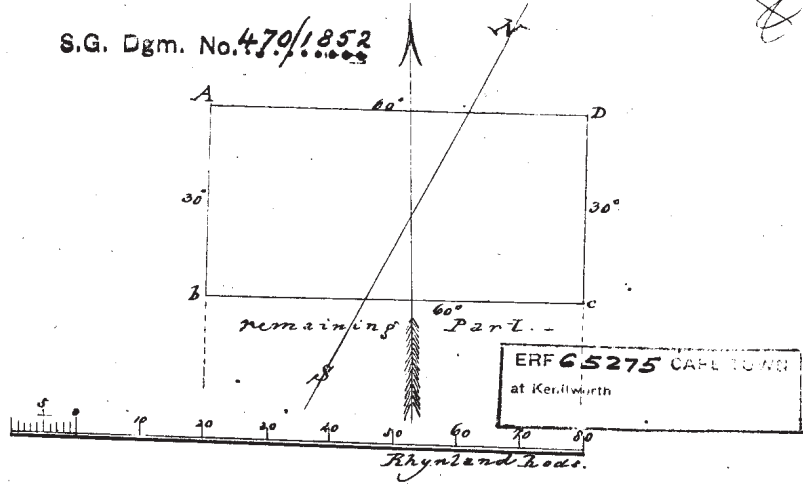

The above Diagram ABCD represents 3 Morgens of Land situate in the Cape Division, in the Plain East of Wynberg, being Part of the Property of the French Republic of Senegal now called Meritonius Martijn;

Extending NE. towards the Village called Claremont, NW. towards the Wynberg, SE. towards the Laquer valley, and S. to the remainder of the said Property. -

Surveyed and divided according to Diagram on the Perpetual Quitrent Lease dated 3^d Jan. 1815. - by me

J. Humbel
Surveyor

C

NO. 257/1814.

Handwritten mark

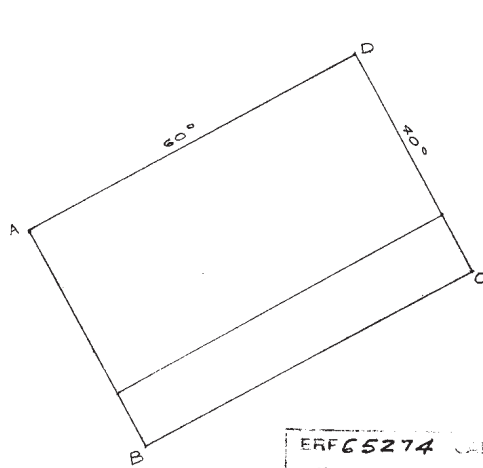

ERF 65274 KAPE TOL
 of Kenilworth



Rhyn. Roeden.

Bovenstaande Figuur, A.B.C.D. vertoond een stuk land,
 gelegen in het Kaapsche Vlakke, be oosten de Wynberg,
 groot in zyn grond 4 Morgen.

Gemeeten den 22nd July, 1814 door my,
 (Get.) J.F. Kirsten, Senior,
 G. G. Landmeter.

Gecopieerd door my,
 (Get.) Jno. Melvill.
 Gezw. Gov. Landmeter.

C

M 3160

Alhier is vermeld wienes Landmeter word
 G/B. C.Q.2-31
 Datum 3.1.1815.
 1/1/1959

AH 1 BB
 V. 51
 For list of
 vedertouwen en
 ook if Diagram

CHECKED
 DATA CHECKED
 ERF 65274
 Comp. V51
 Ref. d1

H. de K./P.S.

PROVINSIALE KENNISGEWING

P.K. 67/2021

18 Junie 2021

DEPARTEMENT VAN OMGEWINGSAKE EN ONTWIKKELINGSBEPLANNING

“NATIONAL ENVIRONMENTAL MANAGEMENT: PROTECTED AREAS ACT, 2003” (WET 57 VAN 2003)

KENNISGEWING VAN VOORNEME OM KENILWORTH NATUURRESERVAAT TE VERKLAAR

Die Provinsiale Minister van Plaaslike Regering, Omgewingsake en Ontwikkelingsbeplanning in die Wes-Kaap—

(a) gee kragtens artikel 33(1)(a) van die “National Environmental Management: Protected Areas Act, 2003” (Wet 57 van 2003), kennis van die voorneme om die Kenilworth Natuurreservaat ingevolge artikel 23(1)(a)(i) van daardie Wet te verklaar op:

1. Restant van Erf 65238 Kenilworth, geleë in die Stad Kaapstad Munisipaliteit, Afdeling Kaap, Provinsie Wes-Kaap;
Groot: 95, 7312 (Vyf-en-Neëntig komma Sewe Drie Een Twee) hektaar;
Gehou kragtens Transportakte Nr T41588/2013;
2. Erf 65275 Kenilworth, geleë in die Stad Kaapstad Munisipaliteit, Afdeling Kaap, Provinsie Wes-Kaap;
Groot: 2, 5696 (Twee komma Vyf Ses Nege Ses) hektaar;
Gehou kragtens Transportakte Nr T41588/2013; en
3. Restant van Erf 65274 Kenilworth, geleë in die Stad Kaapstad Munisipaliteit, Afdeling Kaap, Provinsie Wes-Kaap;
Groot: 8 565 (Ag Duisend Vyf Honderd Vyf-en-Sestig) vierkante meter;
Gehou kragtens Transportakte Nr T41588/2013.

Die eiendom is geleë tussen Doncasterweg in die noorde, Kromboomparkweg in die ooste, Wettonweg in die suide en Rosmeadlaan in die weste, in die buurt Kenilworth ongeveer 10 kilometer suid-oos van Kaapstad se sentrale besigheidsdistrik.

Die grense van die natuurreservaat word weergegee op die Landmeter-generaaldigramme 3137/1882, 470/1852 en 257/1814, soos uiteengesit in die Bylae, en is ook aanlyn beskikbaar by <https://www.capenature.co.za/care-for-nature/stewardship/>; en

(b) nooi lede van die publiek om binne 60 dae vanaf die datum van publikasie van hierdie kennisgewing in die *Provinsiale Koerant* skriftelik versoë te rig oor of beswaar aan te teken teen die voorgestelde verklaring van die Kenilworth Natuurreservaat, deur—

(i) die versoë of besware te pos aan:

Die Hoof- Uitvoerende Beampte
Aandag: Me M Owies
CapeNature
Privaat Sak X29
Gatesville 7766;

(ii) die versoë of besware te e-pos na:
mowies@capenature.co.za;

(iii) die versoë of besware te faks na:
Faksnommer: 086 719 3581; of

(iv) die versoë of besware af te lewer by:
Me M Owies
CapeNature
Hv Bosduif- en Volstruisstraat
Bridgetown
Athlone 7764.

BYLAE

The numerical data of this diagram are sufficiently consistent.
(Sgd.) Max Jurisch
Examiner

S. G. Dgm. No. 3137/1882

S.G.Dgm. No. 3137/1882.

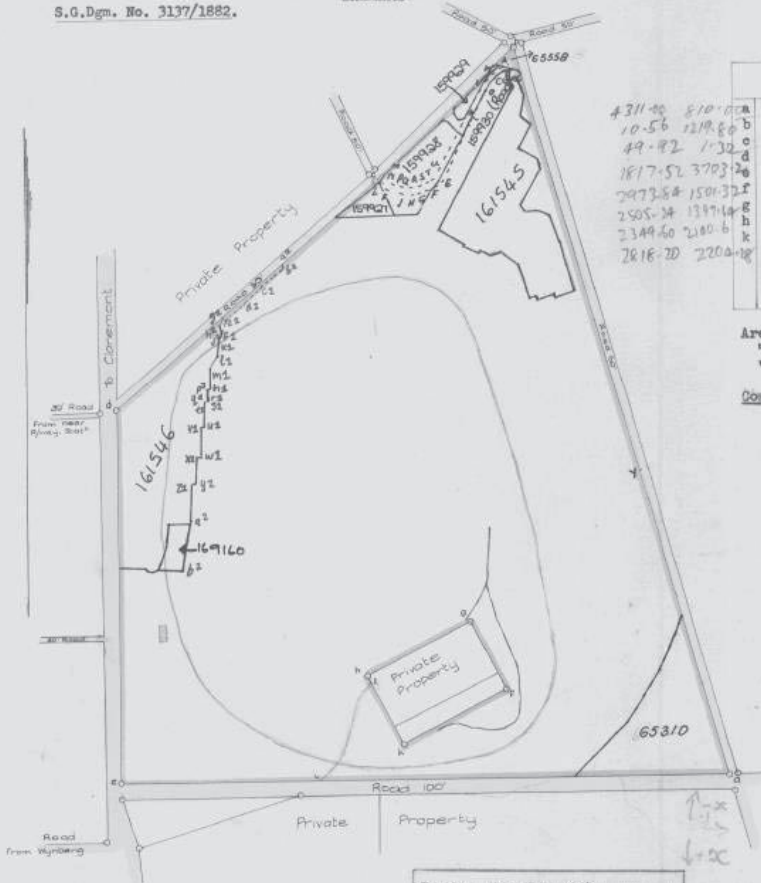

4311.88 810.00
 10.56 1219.80
 49.82 1.32
 1817.52 3703
 2973.84 1501.32
 2505.34 1397.14
 2349.60 2180.6
 2816.20 2200.18

Co-ordinates	Sides	Angles
a - 359.25 + 67.90	ab 397.88	a 74.24.10
b + 0.88 - 101.65	bc 101.67	b 62.0.0
c - 4.16 - 0.11	cd 180.95	c 182.50.30
d - 4.16 + 180.84	de 194.99	d 130.56.10
e - 151.46 + 308.60	ea 318.28	e 89.49.10
f - 247.82 + 125.11	fg 40.00	f 270.0.0
g - 208.77 + 116.47	gh 60.00	g 270.0.0
h - 195.80 + 175.05	hk 40.00	h 270.0.0
k - 234.85 + 183.69	kf 60.00	k 270.0.0
	fa 125.44	afk 129.49.10
	ke 150.19	kfe 201.14.50
		ken 7.1.40
		ekf 21.54.20

Area of fig. a-e 135^w 15^h
 " " " f-k 4.0
 " on the ground 131-15

Condition. A road must be reserved to give access to the farm f - k.

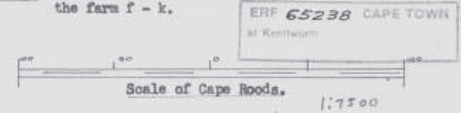

112,2271 ha

The above figure a - e surrounding the figure f.g.h.k. represents 131 Morgen 15 Square Rods of ground, situate in the Cape Division, Field Cornetcy of Newlands on the Claremont Flats.

Bounded North by a Road 50' wide
 East " Do. Do.
 South " Do. 100' wide
 West " Do. Do.

Framed from actual Survey,
 (Sgd.) Wm. de Smidt Junr.
 Gov. Land Surveyor.
 24 November 1882.

Note: The land f g h k is quitrent granted 3rd January, 1815 to Moses Eyssen.

Copied from the diagram relating to
 Title Deed No. C. F. 18. 1.
 dated 18th December, 1882, in favour of
 Chairman in Trust for Jockey Club
 W.S. Handrick
 IN SURVEYOR-GENERAL
 CAPE TOWN.
 4. 6. 1951.

Road interest along Edy... X.Y.
 closed. Vide T/C's Notice d.d. 1993-05-25
 File S/ 9991/48 p.72
 RAJ 1999.07.09
 for SURVEYOR-GENERAL DATE

Cape Town Sheet N 18.

Vol 17. 14192
 152 + 151

M 3160
 M 1425
 ERF 65238
 Cont. 253
 Ref. C6
 FOR ENDORSEMENTS
 SEE BACK OF DIAGRAM

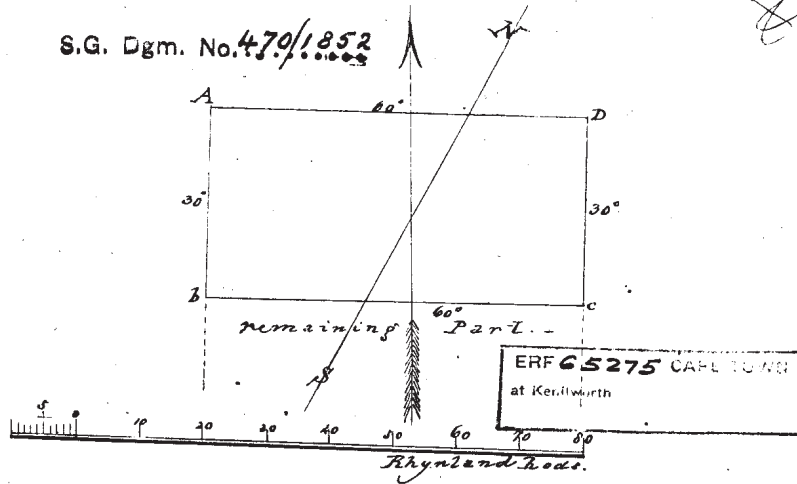

The above Diagram ABCD represents 3 Morgens of Land situate in the Cape Division, in the Plain East of Wynberg, being Part of the Property of the French Republic of Senegal now called Meritonius Martijn;

Extending NE. towards the Village called Claremont, NW. towards the Wynberg, SE. towards the Laquer valley, and S. to the remainder of the said Property. -

Surveyed and divided according to Diagram on the Perpetual Quitrent Lease dated 3^d Jan. 1815. - by me

J. H. H. H.
J. H. H. H.

C

NO. 257/1814.

Handwritten mark

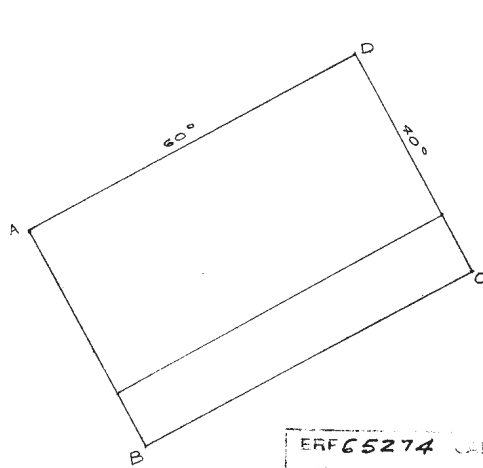

ERF 65274 KAPE TOL
 of Kops-wortel



Rhyn. Roeden.

Bovenstaande Figuur, A.B.C.D. vertoond een stuk land,
 geleegen in het Kaapsche Vlakke, be oosten de Wynberg,
 groot in zyn grond 4 Morgen.

Gemeeten den 22nd July, 1814 door my,
 (Get.) J.F. Kirsten, Senior,
 G. G. Landmeter.

Gecopieerd door my,
 (Get.) Jno. Melvill.
 Gezw. Gov. Landmeter.

C

M 3160

Alhier is vermeld wienes Landmeter word
 G/B. C.Q.2-31
 Datum 3.1.1815.
 G.G. Landmeter
 1/1/1959

AH 1 BB
 V. 51
 For list of
 vedertouwen en
 ook if Diagram

CHECKED
 DATA CHECKED
 12-2-60
 ERF 65274
 Comp. V51
 Ref. d1

H. de K./P.S.

ISAZISO SEPHONDO

I.S. 67/2021

18 kweyeSilimela 2021

ISEBE LEMICIMBI YOKUSINGQONGILEYO NOCWANGCISO LOPHUHLISO**ULAWULO LWENDALO ESINGQONGILEYO: UMTHEHO WEMIMANDLA EKHUSELWEYO, 2003 (UMTHEHO 57 KA-2003)****ISAZISO SENJONGO YOKUBHENGEZA INDAWO YEZOLONDOLOZO LWENDALO YASEKENILWORTH**

UMphathiswa wePhondo woRhulumente weNgingqi, iMicimbi yokuSingqongileyo noCwangciso loPhuhliso eNtshona Koloni—

(a) phantsi kwecandelo 33(1)(a) lomthetho uLawulo lweNdalo esiNgqongileyo: UMthetho weMimandla eKhuselweyo, 2003 (uMthetho 57 ka-2003), ukhupha isaziso esingenjongo yokubhengeza iNdawo yezoLondolozo lweNdalo yaseKenilworth, ngokwecandelo 23(1)(a)(i) loMthetho:

1. Kwintsalela yesiza 65238 eKenilworth, esiphantsi koMasipala weSixeko saseKapa, iCandelo lePhondo laseKapa, kwiPhondo laseNtshona Koloni;
Kubungakanani: 95, 7312 (AmaShumi aliThoba aneSihlanu, ikoma iSixhenxe iSithathu iSinye iSibini) seehektare;
Egcinwe phantsi kwetayitile yobunini engonikezelo enguNomb. T41588/2013;
2. KwiSiza 65275 eKenilworth, esiphantsi koMasipala weSixeko saseKapa, kwiPhondo laseNtshona Koloni;
Kubungakanani: 2, 5696 (iSibini ikhoma iSihlanu iSithoba iSithandathu) seehektare;
Esiphantsi kweTayitile yoBunini enguNomb. T41588/2013; kunye
3. Nakwintaselela yeSiza 65274 eKenilworth, esiphantsi koMasipala weSixeko saseKapa, kwiPhondo laseNtshona Koloni, iCandelo laseKapa, iPhondo laseNtshona Koloni;
Kubungakanani: 8 565 (Amawaka aSibhozo amaKhulu amaHlanu namaShumi amaThandathu aneSihlanu) seeskwenitha;
Esiphantsi kweTayitile yoBunini enguNomb. T41588/2013.

Iipropati zithi zifumaneka phakathi kweDoncaster Road ukuya emntla, Kromboom Parkway ukuya empuma, Wetton Road ukuya emzantsi naseRosmead Avenue ukuya entshona, idolophana iKenilworth emalunga neekhilomitha ezili-10 kumzantsi mpuma weSithili esikuMbindi weKapa.

Imida yendawo yolondolozo ndalo iboniswa kwiidayagramu zikaNocanda-Jikelele 3137/1882, 470/1852 no-257/1814 njengoko kubonisiwe kwiShedyuli, kwaye zingabonwa ku-<https://www.capenature.co.za/care-for-nature/stewardship/>; kwaye

- (b) uhlaba ikhwelo kumalungu oluntu ukuba angenise izingeniso ezibhaliweyo okanye angenise izichaso ezijoliswe kwisiphakamiso sokubhengezwa kweNdawo yezoLondolozo lweNdalo yaseKenilworth, kwiintsuku ezingama-60 ukususela kumhla wokupapashwa kwesi sibhengezo kwiGazethi yePhondo, ngokuthi—
- (i) kuposwe izingeniso okanye izichaso:
 - kwiGosa eliyiNtloko leSigqeba
 - Zijoliswe: kuNksz M Owies
 - CapeNature
 - Private Bag X29
 - Gatesville 7766;
 - (ii) kuposwe izingeniso okanye izichaso kwa:
 - mowies@capenature.co.za;
 - (iii) kufeksewe izingeniso okanye izichaso kwa:
 - 086 719 3581; okanye
 - (iv) uzinikezele ngokwakho izingeniso okanye izichaso:
 - kuNksz M Owies
 - CapeNature
 - Kwikona yeBosduif neVolstruis Streets
 - Bridgetown
 - Athlone 7764.

ISHEDYULI

The numerical data of this diagram are sufficiently consistent.
(Sgd.) Max Jurisch
Examiner

S. G. Dgm. No. 3137/1882

S.G.Dgm. No. 3137/1882.

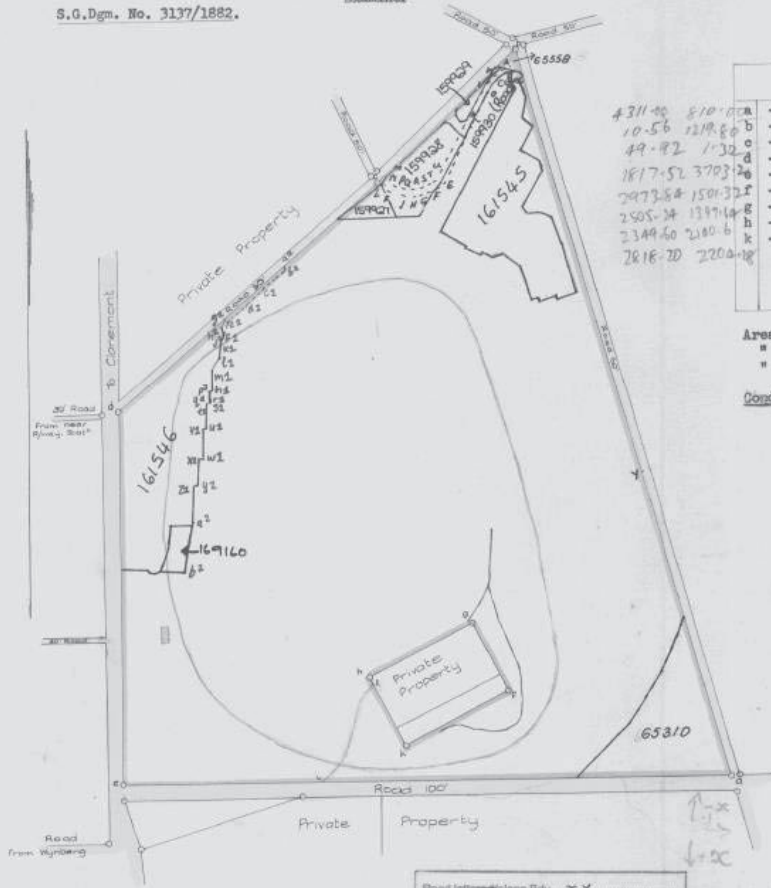

4311.80 810.00
 10.56 1218.80
 49.82 1532
 1817.52 3783.20
 2973.58 1501.32
 2505.34 1347.14
 2349.60 2180.6
 2818.70 2200.18

Co-ordinates	Sides	Angles
a - 359.25 + 67.90	ab 397.88	a 74.24.10
b + 0.88 - 101.65	bc 101.67	b 62.0.0
c - 4.16 - 0.11	cd 180.95	c 182.50.30
d - 4.16 + 180.84	de 194.99	d 130.56.10
e - 151.46 + 308.60	ea 318.28	e 89.49.10
f - 247.82 + 125.11	fg 40.00	f 270.0.0
g - 208.77 + 116.47	gh 60.00	g 270.0.0
h - 195.80 + 175.05	hk 40.00	h 270.0.0
k - 234.85 + 183.69	ka 60.00	k 270.0.0
	fa 125.44	afk 129.49.10
	ke 150.19	fke 201.14.50
		ken 7.1.40
		esf 21.54.20

Area of fig. a-e = 135^v 15^h
 " " " f-k = 4^v 0^h
 " on the ground 131-15

Condition. A road must be reserved to give access to the farm f - k.

ERF 65238 CAPE TOWN
at Kenilworth

Scale of Cape Roads. 1:7500
112,2271 ha

The above figure a - e surrounding the figure f,g,h,k, represents 131 Morgen 15 Square Roods of ground, situate in the Cape Division, Field Cornetcy of Newlands on the Claremont Flats.

Bounded North by a Road 50' wide
 East " Do. Do.
 South " Do. 100' wide
 West " Do. Do.

Framed from actual Survey,
 (Sgd.) Wm. de Smidt Junr.
 Gov. Land Surveyor.
 24 November 1882.

Road reserved along Bdy... X.Y.
 closed. Vide T/C's Notice d.d. 1993-05-25
 File 6/3391/48 p.72
 RAZ 1999.07.09
 for SURVEYOR-GENERAL DATE

Copied from the diagram relating to
 Title Deed No. C. F. 18. 1.
 dated 18th December, 1882, in favour of
 Chairman in Trust for Jockey Club
 W. G. Hardwick
 SURVEYOR-GENERAL
 CAPE TOWN.
 4-6-1951.

Cape Town Sheet N 18.

Note: The land f g h k is Quitrent granted 3rd January, 1815 to Moses Eysen.

M 3160

M 1426

ERF 65238
Comp. 253
Ref. C6

FOR ENDORSEMENTS
SEE BACK OF DIAGRAM

Vol 17. 14102
182 + 181

BS

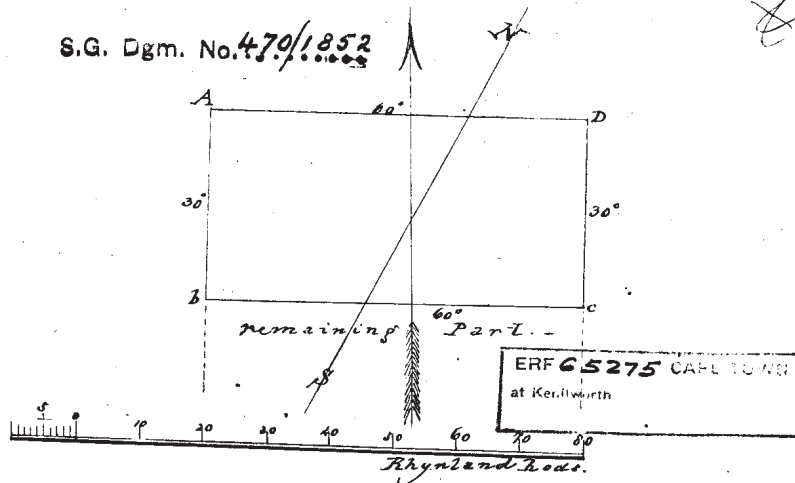

The above Diagram ABCD represents 3 Morgens of Land situate in the Cape Division, in the Plain East of Wynberg, being Part of the Property of the French Republic of Senegal now called Meritonius Martijn;

Extending NE. towards the Village called Claremont, NW. towards the Wynberg, SE. towards the Laquer valley, and S. to the remainder of the said Property. -

Surveyed and divided according to Diagram on the Perpetual Quitrent Lease dated 3^d Jan. 1815. - by me

J. H. H. H.
J. H. H. H.

C

NO. 257/1814.

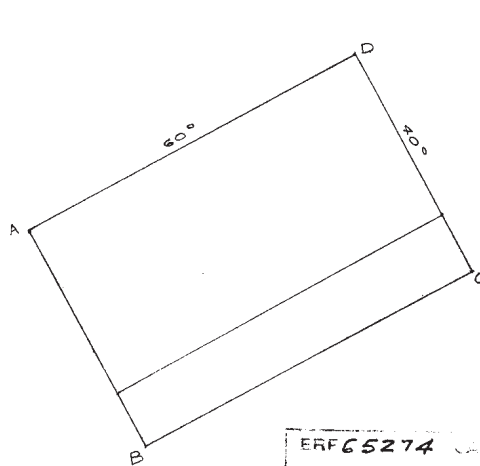

ERF 65274 KAPE TOLIN
of Kenilworth



Rhyn. Roeden.

Bovenstaande Figuur, A.B.C.D. vertoond een stuk land,
geleegen in het Kaapsche Vlakke, be oosten de Wynberg,
groot in zyn grond 4 Morgen.

Gemeeten den 22nd July, 1814 door my,

(Get.) J.F. Kirsten, Senior,

G. G. Landmeter.

Gecopieerd door my,

(Get.) Jno. Melvill.

Gezw. Gov. Landmeter.

C

M 3160

Affiche van de Staat...
G/B... C.Q.2-31
3.1.1815.
1/1/1959

AH 1 BB
V. 51
For list of
revisions to
this diagram

CHECKED
DATA CHECKED
ERF 65274
Comp. V51
Ref. d1

H. de K./P.S.

PROVINCIAL NOTICE

P.N. 68/2021

18 June 2021

**DEPARTMENT OF ENVIRONMENTAL AFFAIRS AND DEVELOPMENT PLANNING
NATIONAL ENVIRONMENTAL MANAGEMENT: PROTECTED AREAS ACT, 2003 (ACT 57 OF 2003)****NOTICE OF INTENTION TO DECLARE TWEE RIVIEREN NATURE RESERVE**

The Provincial Minister of Local Government, Environmental Affairs and Development Planning in the Western Cape—

(a) under section 33(1)(a) of the National Environmental Management: Protected Areas Act, 2003 (Act 57 of 2003), gives notice of the intention to declare the Twee Rivieren Nature Reserve in terms of section 23(1)(a)(i) of that Act on:

1. The Farm Pompieshoek No. 63, situated in the Witzenberg Municipality, Division of Ceres, Western Cape Province;
In extent: 4740, 4036 (Four Thousand Seven Hundred and Forty comma Four Zero Three Six) hectares;
Held by Title Deed No. T17477/2018;
2. Portion 25 of the Farm Twee Riviers Drift No. 62, situated in the Witzenberg Municipality, Division of Ceres, Western Cape Province;
In extent: 666, 2779 (Six Hundred and Sixty-Six comma Two Seven Seven Nine) hectares;
Held by Title Deed No. T40393/2018;
3. Remainder of Portion 3 (a portion of Portion 1) of the Farm Twee Riviers Drift No. 62, situated in the Witzenberg Municipality, Division of Ceres, Western Cape Province;
In extent: 406, 8524 (Four Hundred and Six comma Eight Five Two Four) hectares;
Held by Title Deed No. T55449/2008;
4. Portion 24 (a portion of Portion 2) of the Farm Twee Riviers Drift No. 62, situated in the Witzenberg Municipality, Division of Ceres, Western Cape Province;
In extent: 37, 4243 (Thirty-Seven comma Four Two Four Three) hectares;
Held by Title Deed No. T50444/2015;
5. Remainder of the Farm Twee Riviers Drift No. 62, situated in the Witzenberg Municipality, Division of Ceres, Western Cape Province;
In extent: 1444, 9996 (One Thousand Four Hundred and Forty-Four comma Nine Nine Nine Six) hectares;
Held by Title Deed No. T31687/1993;
6. Portion 1 of the Farm Zandfonteinberg No. 49, situated in the Witzenberg Municipality, Division of Ceres, Western Cape Province;
In extent: 646, 0909 (Six Hundred and Forty-Six comma Zero Nine Zero Nine) hectares;
Held by Title Deed No. T24464/2019; and
7. Remainder of the Farm Zandfonteinberg No. 49, situated in the Witzenberg Municipality, Division of Ceres, Western Cape Province;
In extent: 1416, 8199 (One Thousand Four Hundred and Sixteen comma Eight One Nine Nine) hectares;
Held by Title Deed No. T96131/1997.

The properties are owned by several private landowners and are situated approximately 90 km north of the town of Ceres along the R303, in the Cederberg region.

The boundaries are reflected on Surveyor-General diagram 7/2020, as set out in the Schedule, and may also be viewed at: <https://www.capenature.co.za/care-for-nature/stewardship/>; and

(b) invites members of the public to submit written representations on or objections to the proposed declaration of the Twee Rivieren Nature Reserve within 60 days from the date of publication of this notice in the *Provincial Gazette* by—

- (i) posting the representations or objections to:

The Chief Executive Officer
Attention: Ms T Paleker
CapeNature
Private Bag X29
Gatesville 7766;

- (ii) e-mailing the representations or objections to:
tpaleker@capenature.co.za;

- (iii) faxing the representations or objections to:
Fax number: 086 719 3581; or

- (iv) delivering the representations or objections to:
Ms T Paleker
CapeNature
Cnr Bosduif and Volstruis Streets
Bridgetown
Athlone 7764.

SCHEDULE

FRAMED FOR PROCLAMATION PURPOSES - ACT 57/2003

Point	Coordinates	Coordinates
Letter	X	Y
A	3 586,17	332,22,33
B	3 381,21	328,22,33
C	3 023,18	324,21,33
D	1 937,80	321,21,33
E	7 037,58	316,43,33
F	6 162,58	312,11,33
G	5 413,01	308,11,33
H	3 312,11	304,11,33
I	1 946,21	291,10,33
J	1 372,62	281,10,33
K	2 452,47	255,29,33
L	1 472,76	242,29,33
M	942,20	222,29,33
N	3 238,02	201,30,33
O	3 276,17	202,30,33
P	3 097,47	204,30,33
Q	3 044,01	202,30,33
R	3 044,01	202,30,33
S	3 044,01	202,30,33
T	3 044,01	202,30,33
U	3 044,01	202,30,33
V	3 044,01	202,30,33
W	3 044,01	202,30,33
X	3 044,01	202,30,33
Y	3 044,01	202,30,33
Z	3 044,01	202,30,33

PLAN NO. 7/2020

Scale 1 : 40 000

CERTIFIED COPY FOR REGISTRATION
 FOR SURVEYOR-GENERAL *Dieter*
 DATE 19-02-2020

S.S. No.
7/2020
Approved
Dieter
for Surveyor-General
2020-02-18

SCHEDULE OF PRIORITIES

Description of figure subject to Nature Reserve	Area	Farm	Diagram No.	Deed of Transfer
31 A B C U T S Z V X e d c b a	1436,8199ha	Residue of the farm Zandfontein No.49 (the whole)	570/889	Grant. Co. 0-4-21
32 B C F G H	6740,4039ha	The farm Pongas Heel No.60 (the whole)	5/27/889	Grant. Co. 0-3-18
33 J K L Y G C I B I A I h j	498,3621ha	Residue portion 3 of the farm Tsee Rivers Drift No.62 (the whole)	8153/840	1961, 528
41 P R V C B a h	3042,39a	Residue of the farm Tsee Rivers Drift No.62	8/57/889	Grant. Co. 0-2-16
51 # P Q R a b c d a	846,0809ha	Portion 1 of the farm Zandfontein No.49 (the whole)	2722/1948	1948, 2943
61 J P g h j	37,2429ha	Portion 26 of the farm Tsee Rivers Drift No.62 (the whole)	4479/2010	2010, 5043
71 K H H j g r t z	696,2779ha	Portion 25 of the farm Tsee Rivers Drift No.62 (the whole)	4487/2010	2010, 5043

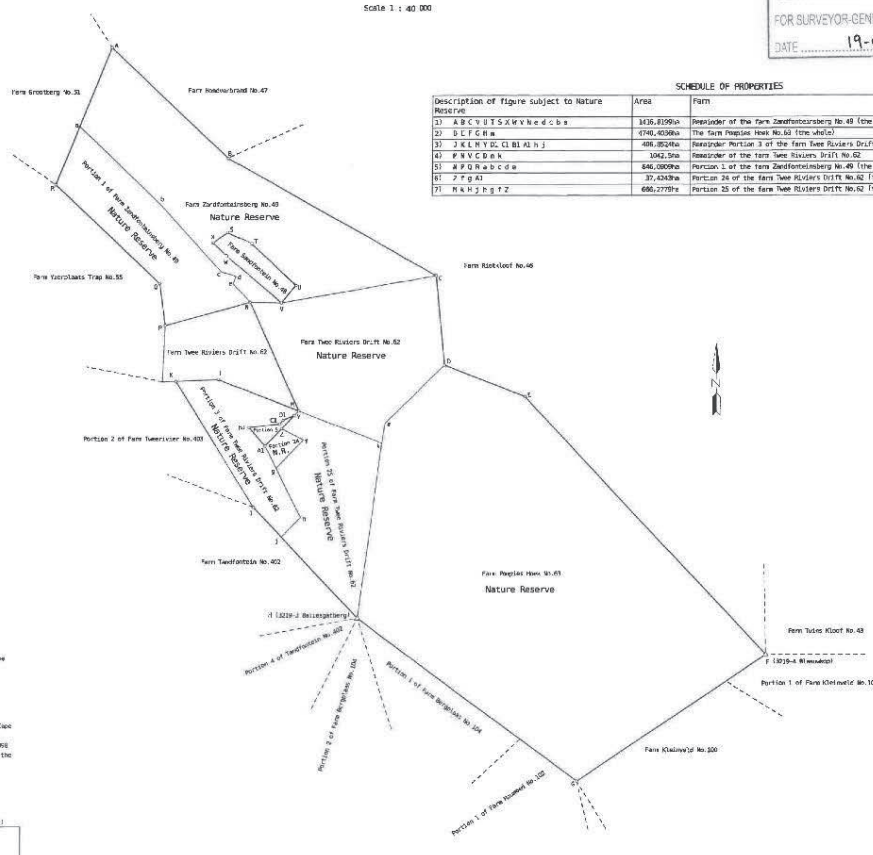

The figure A B C D E F G H J K L M P Q R a b c d e f g h i j k l m n o p q r s t u v w x y z and 1 2 3 4 5 6 7 8 9 10 11 12 13 14 15 16 17 18 19 20 21 22 23 24 25 26 27 28 29 30 31 32 33 34 35 36 37 38 39 40 41 42 43 44 45 46 47 48 49 50 51 52 53 54 55 56 57 58 59 60 61 62 63 64 65 66 67 68 69 70 71 72 73 74 75 76 77 78 79 80 81 82 83 84 85 86 87 88 89 90 91 92 93 94 95 96 97 98 99 100

over the farms as listed in the Schedule of Farms situated in the Witsand Municipality, Agricultural District of Colesberg, Province of the Western Cape.

Drawn on November 2019 in terms of Section 15 of the Land Survey Act 7 of 1958 for the purpose of establishing a Nature Reserve in terms of Section 21(1) of the National Environmental Management: Protected Areas Act 57 of 2003 by etc.

Professional Land Surveyor (F.S. Rating) (N.C. 2534)
 No. 4044
 No. 4044
 No. 4044

PROVINSIALE KENNISGEWING

P.K. 68/2021

18 Junie 2021

DEPARTEMENT VAN OMGEWINGSAKE EN ONTWIKKELINGSBEPLANNING

“NATIONAL ENVIRONMENTAL MANAGEMENT: PROTECTED AREAS ACT, 2003” (WET 57 VAN 2003)

KENNISGEWING VAN VOORNEME OM TWEË RIVIEREN NATUURRESERVAAT TE VERKLAAR

Die Provinsiale Minister van Plaaslike Regering, Omgewingsake en Ontwikkelingsbeplanning in die Wes-Kaap—

(a) gee kragtens artikel 33(1)(a) van die “National Environmental Management: Protected Areas Act, 2003” (Wet 57 van 2003), kennis van die voorneme om die Twee Rivieren Natuurreservaat ingevolge artikel 23(1)(a)(i) van daardie Wet te verklaar op:

1. Die Plaas Pompieshoek Nr. 63, geleë in die Witzenberg Munisipaliteit, Afdeling Ceres, Provinsie Wes-Kaap;
Groot: 4740, 4036 (Vier Duisend Sewe Honderd en Veertig komma Vier Nul Drie Ses) hektaar;
Gehou kragtens Transportake Nr. T17477/2018;
2. Gedeelte 25 van die Plaas Twee Riviers Drift Nr. 62, geleë in die Witzenberg Munisipaliteit, Afdeling Ceres, Provinsie Wes-Kaap;
Groot: 666, 2779 (Ses Honderd Ses-en-Sestig komma Twee Sewe Sewe Nege) hektaar;
Gehou kragtens Transportakte Nr. T40393/2018;
3. Restant van Gedeelte 3 (*n gedeelte van Gedeelte 1) van die Plaas Twee Riviers Drift Nr. 62, geleë in die Witzenberg Munisipaliteit, Afdeling Ceres, Provinsie Wes-Kaap;
Groot: 406, 8524 (Vier Honderd en Ses komma Agt Vyf Twee Vier) hektaar;
Gehou kragtens Transportakte Nr. T55449/2008;
4. Gedeelte 24 (*n gedeelte van Gedeelte 2) van die Plaas Twee Riviers Drift Nr. 62, geleë in the Witzenberg Munisipaliteit, Afdeling Ceres, Provinsie Wes-Kaap;
Groot: 37, 4243 (Sewe-en-Dertig komma Vier Twee Vier Drie) hektaar;
Gehou kragtens Transportakte Nr. T50444/2015;
5. Restant van die Plaas Twee Riviers Drift Nr. 62, geleë in die Witzenberg Munisipaliteit, Afdeling Ceres, Provinsie Wes-Kaap;
Groot: 1444, 9996 (Een Duisend Vier Honderd Vier-en-Veertig komma Nege Nege Nege Ses) hektaar;
Gehou kragtens Transportakte Nr. T31687/1993;
6. Gedeelte 1 van die Plaas Zandfonteinberg Nr. 49, geleë in die Witzenberg Munisipaliteit, Afdeling Ceres, Provinsie Wes-Kaap;
Groot: 646, 0909 (Ses Honderd Ses-en-Veertig komma Nul Nege Nul Nege) hektaar;
Gehou kragtens Transportakte Nr. T24464/2019; en
7. Restant van die Plaas Zandfonteinberg Nr. 49, geleë in the Witzenberg Munisipaliteit, Afdeling Ceres, Provinsie Wes-Kaap;
Groot: 1416, 8199 (Een Duisend Vier Honderd en Sestien komma Agt Een Nege Nege) hektaar;
Gehou kragtens Transportakte Nr. T96131/1997.

Die eiendomme word deur verskeie privaat grondeienaars besit en is ongeveer 90 km noord van die dorp Ceres geleë, langs die R303, in die Cederberg-streek.

Die grense word weergegee op Landmeter-generaal diagram 7/2020, soos uiteengesit in die Bylae, en kan ook gevind word by:
<https://www.capenature.co.za/care-for-nature/stewardship/>; en

(b) nooi lede van die publiek om, binne 60 dae vanaf die datum van publikasie van hierdie kennisgewing in die *Provinsiale Koerant*, skriftelike verhoë te rig oor of beswaar aan te teken teen die voorgestelde verklaring van die Twee Rivieren Natuurreservaat deur—

(i) die verhoë of besware te pos aan:
Die Hoof- Uitvoerende Beampste
Aandag: Me T Paleker
CapeNature
Privaat Sak X29
Gatesville 7766;

(ii) die verhoë of besware te e-pos na:
tpaleker@capenature.co.za;

(iii) die verhoë of besware te faks na:
Faksnommer: 086 719 3581; of

(iv) die verhoë of besware af te lewer by:
Me T Paleker
CapeNature
Hv Bosduif- en Volstruisstraat
Bridgetown
Athlone 7764.

ISAZISO SEPHONDO

I.S. 68/2021

18 kweyeSilimela 2021

ISEBE LEMICIMBI YOKUSINGQONGILEYO NOCWANGCISO LOPHUHLISO**ULAWULO LWENDALO ESINGQONGILEYO: UMTHEHO WEMIMANDLA EKHUSELWEYO, 2003 (UMTHEHO 57 KA-2003)****ISAZISO SENJONGO YOKUBHENGEZWA KWETWEE RIVIEREN NJENGENDAWO YOLONDOLOZO LWENDALO**

UMphathiswa wePhondo woRhulumente weNgingqi, iMicimbi yokuSingqongileyo noCwangciso loPhuhliso, eNtshona Koloni—

(a) Phantsi kwecandelo 33(1)(a) loMthetho woLawulo lokusiNggongileyo kaZwelonke: UMthetho weMimandla eKhuselweyo, 2003 (uMthetho 57 ka-2003), unika isaziso senjongo sokubhengezwa kweTwee Rivieren njengendawo yolondolozo lwendalo ngokwecandelo 23(1)(a)(i) yaloo Mthetho kwi:

1. Fama iPompieshoek enguNombolo 63, imi kuMasipala waseWitzenberg, kwiCandelo laseCeres, kwiPhondo laseNtshona Koloni;
Ububanzi bayo buzihekthare ezinga- 4740, 4036 (Amawaka amane anekhulu elisiXhenxe namashumi amane);
Itayitile yomnini enguNombolo: T17477/2018;
2. Sahlulo sama-25 seFama iTwee Riviers Drift enguNombolo 62, imi kuMasipala waseWitzenberg, kwiCandelo laseCeres, kwiPhondo leNtshona Koloni;
Ububanzi bayo buzihekthare ezinga- 666, 2779 (Amakhulu amathandathu anamashumi amathandathu anesithandathu);
Itayitile yomnini enguNombolo: T40393/2018;
3. Ntsalela yenxalenye yesi-3 (isahlulo seSahlulo soku-1) seFama iTwee Riviers Drift enguNombolo 62, ime kuMasipala waseWitzenberg, kwiCandelo laseCeres, kwiPhondo leNtshona Koloni;
Ububanzi bayo buzihekthare ezinga- 406, 8524 (Amakhulu amane anesithandathu);
Itayitile yomnini enguNombolo: T55449/2008;
4. Sahlulo sama-24 (isahlulo seSahlulo se-2) seFama iTwee Riviers Drift enguNombolo 62, imi kuMasipala waseWitzenberg, kwiCandelo laseCeres, kwiPhondo leNtshona Koloni;
Ububanzi bayo buzihekthare ezinga- 37, 4243 (Amashumi amathathu anesixhenxe);
Itayitile yomnini enguNombolo: T50444/2015;
5. Ntsalela yeFama iTwee Riviers Drift enguNombolo 62, ime kuMasipala waseWitzenberg, kwiCandelo laseCeres, kwiPhondo leNtshona Koloni;
Ububanzi bayo buzihekthare ezinga- 1444, 9996 (Iwaka elinamakhulu amane anesine namashumi amane);
Itayitile yomnini enguNombolo: T31687/1993;
6. Sahlulo soku-1 seFama iZandfonteinberg esinguNombolo 49, emi kuMasipala waseWitzenberg, kwiCandelo laseCeres, kwiPhondo leNtshona Koloni;
Ububanzi bayo buzihekthare ezinga- 646, 0909 (Amakhulu Amathandathu anamashumi amane anesithandathu);
Itayitile yomnini enguNombolo: T24464/2019; kunye ne
7. Ntsalela yeFama iZandfonteinberg esinguNombolo 49, imi kuMasipala waseWitzenberg, kwiCandelo laseCeres, kwiPhondo leNtshona Koloni;
Ububanzi bayo buzihekthare ezinga- 1416, 8199 (Iwaka elinamakhulu amane aneshumi elinesithandathu);
Itayitile yomnini enguNombolo: T96131/1997.

Iziza ezicongiweyo zezabanini mhlaba babucala abaliqela kwaye zimi malunga nomgama ongama-90 km kumntla wedolophu yaseCeres ecaleni kwe-R303, kwingingqi yaseCederberg.

Imida ibonakalisiwe kumzobo kaNocanda-Jikelele 7/2020, njengoko ucacisiwe kule Shedyuli, kwaye zinokujongwa apha: <https://www.capenature.co.za/care-for-nature/stewardship/>; kwaye

(b) kumenywa uluntu ukuba lungenise izimvo ezibhaliweyo kanye nezichaso olunazo malunga nesi sibhengezo esicitywayo sendawo yolondolozo lwendalo seTwee Rivieren zingaphelanga iintsuku ezingama-60 ukusukela kumhla wopapasho lwesi saziso kwiGazethi yePhondo ngoku—

(i) Thumela inkxaso okanye inkcaso ku:

IGosa eliyiNtloko lesiGqeba
Ingqalelo: Ms T Paleker
CapeNature
Private Bag X29
Gatesville 7766;

(ii) Thumela i-imeyile ku:
tpaleker@capenature.co.za;

(iii) Thumela ifeksi ku:
Inombolo yefeksi: 086 719 3581; okanye

(iv) ukuhambisa izimvo okanye izichaso ku:
Ms T Paleker
CapeNature
Cnr Bosduif and Volstruis Streets
Bridgetown
Athlone 7764.

